



NEO²

OEM
HVAC

3 SPEED VENTILATION AND TEMPERATURE BY COMPRESSOR CYCLING CONTROL PANEL GL-P8HGL207

CHARACTERISTICS

- 3 speed evaporator power switch 16A@12V and 10A@24V
- Return temperature sensor
- Celcius scale
- Fresh air output
- 5A positive clutch output
- A/C button
- Fresh air button
- Diagnostic LED

- Innovative design
- Designed for heavy-duty applications
- Analog commands
- Backlit buttons and symbols
- Customer logo on the panel (optional)
- Screwless installation
- Automotive connector
- High frontal protection grade- IP 54

TECHNICAL DATA

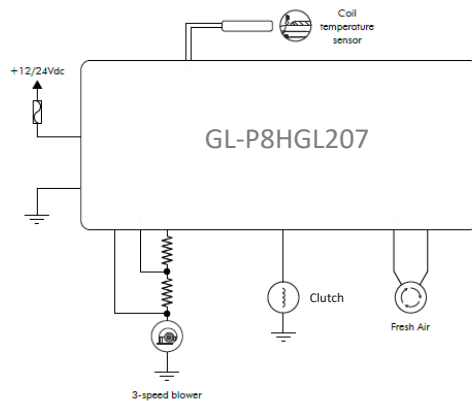
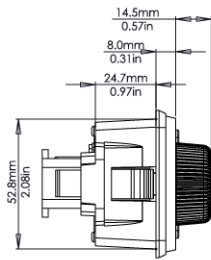
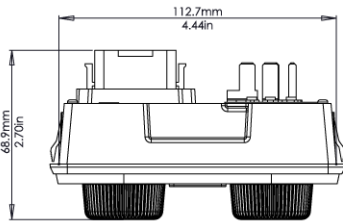

CONNECTORS



3 Speed Power switch
Part Number: 754C3
Manufacturer: KOCH SALES



Mate-N-Lok 15 cable paths
Part Number: 1-480710 - 0
Terminal - PN: 350689-3
Manufacturer: Tyco Electronics

Approximate gross weight: 175 g

TECHNICAL DATA

OPERATING VOLTAGE	12 VDC to 24 VDC
VOLTAGE RANGE	9 VDC to 30 VDC
MAXIMUM VOLTAGE	32 VDC during 5min
MAXIMUM OUTPUT CURRENT	See description above
OUTPUT SHORT CIRCUIT	Protected ***
REVERSE POLARITY	Protected *
OPERATING TEMPERATURE	-40°C to +85°C / -40°F to +185°F
STORAGE TEMPERATURE	-40°C to +125°C / -40°F to +257°F
TEMPERATURE SENSOR	NTC 10K
FRONTAL PROTECTION DEGREE	IP 54
COMMUNICATION	N/A
MAXIMUM CURRENT CONSUMPTION	40mA @ 12VDC, 20mA @ 24VDC **

* According to product specifications.

** Consumption ,may vary according to customer specifications.

*** Except on power switch.

We keep the right to update or change information regarding products without prior notice.